



Caster and Wheel Corporation

TO ORDER OR INQUIRE PLEASE CONTACT

DICK JONES SALES, INC.
258 Baltimore Street PO Box 141
Hanover, PA 17331
800-441-9955
dickjones@dickjonessales.com

MODEL 4200 STEEL TRIPOD DOLLY

Moving equipment in small spaces with tight corners is a challenge for lift trucks or four wheel dolly movers but not for the tripod dolly! This product can navigate tight corners, loading and unloading and streets and buildings. These are compact triangular shaped dollies with a cup center; often called cup dollies or cup casters. One dolly is placed under each post or corner of the article you intend to move; once all dollies are placed you simply roll your article through entry ways, down the street, onto the truck, or across the room! The special swivel wheels and tripod wheel arrangement allow the article to be moved in any direction, where you want them too; safely and securely.

Model 4200 GFPO Steel base dolly

CONSTRUCTION: Price \$276.00/each

DOLLY BODY:

3/8" Thick plate dolly base with 6" inside diameter straight sided well made from 1/4" DOM wall tube with a 3/8" thick welded floor assembly. The well floor has 4 drain holes. Well 2" deep.

CASTERS:

- Attractive zinc plated finish
- 1/2" solid axle with lock nut
- 1/4" steel top plate and fork legs for durability
- Swivel has full double ball hardened raceways
- Grease fitting in the swivel raceway

WHEELS:

- 4" x 2" Injection molded reinforced thermoplastic (GFPO) wheel has the same weight capacity of steel, yet incredibly light-weight and impact resistant.
- Flanged and sealed ball bearings
- 100% washable & steam cleanable; has the best chemical resistance of any wheel, not affected by grease, oils, most chemicals & cleaning solutions, salt, brine & blood.
- Extreme impact strength, good abrasion and compression resistance, will not flat spot.
- Durometer: 65 Shore D (+/-5).
- Temperature range: -45° F to 250° F

WEIGHT CAPACITY: 1500 lbs. per dolly

TEMPERATURE RANGE: -45° F to 250° F

WEIGHT: 35 lbs. each

Model 4200 GFPO

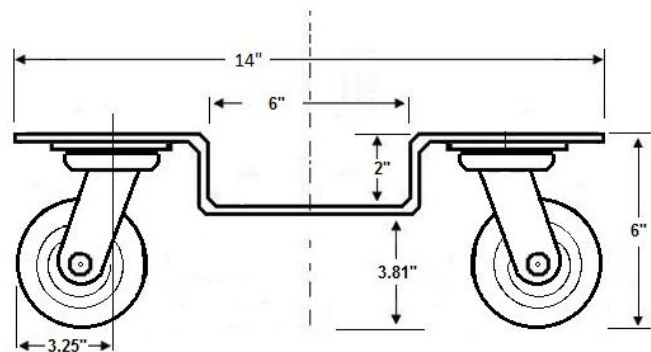

FRONT VIEW

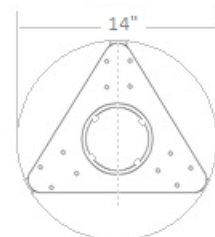

TOP VIEW



Caster and Wheel Corporation

TO ORDER OR INQUIRE PLEASE CONTACT
DICK JONES SALES, INC.
258 Baltimore Street PO Box 141
Hanover, PA 17331
800-441-9955
dickjones@dickjonessales.com

CONSTRUCTION:

DOLLY BODY:

3/8" Thick dolly base plate with 6" inside diameter straight sided well made from 1/4" DOM wall tube with a 3/8" thick welded floor assembly. The well floor has 4 drain holes. Well 2" deep.

CASTERS:

- Attractive zinc plated finish
- 1/2" solid axle with lock nut
- 1/4" steel top plate and fork legs for durability
- Swivel has full double ball hardened raceways
- Grease fitting in the swivel raceway

Model 4200 CI Steel Base Dolly \$308.00/ea

WHEELS:

- 4" x 2" Bond cast iron wheels.
- Flanged and sealed ball bearings
- Temperature range: -50° F to 275° F

WEIGHT CAPACITY: 1500 lbs. per dolly

WEIGHT: 47 lbs. each

Model 4200 PH Steel Base Dolly \$276/ea

WHEELS:

- 4" x 2" Bond phenolic wheels.
- Flanged and sealed ball bearings
- Temperature range: -50° F to 260° F

WEIGHT CAPACITY: 1500 lbs. per dolly

WEIGHT: 37 lbs. each

Model 4200 CI



WEIGHT CAPACITY: 3500 lbs per dolly

TEMPERATURE RANGE: -45 ° to 180 ° F.

WEIGHT: 105 lbs. each

Model 4200 PH



WEIGHT CAPACITY: 3500 lbs per dolly

TEMPERATURE RANGE: -45 ° to 180 ° F.

WEIGHT: 85 lbs. each



Caster and Wheel Corporation

TO ORDER OR INQUIRE PLEASE CONTACT

DICK JONES SALES, INC.
258 Baltimore Street PO Box 141
Hanover, PA 17331
800-441-9955
dickjones@dickjonessales.com

WEIGHT CAPACITY: 3500 lbs per dolly

TEMPERATURE RANGE: -45 ° to 180 ° F.

WEIGHT: 85 lbs. each

CASTERS, WHEELS, TRUCK LOCKS,